

ELECTROFUSION I.C. ELBOW 45°

For Gas/Water-SDR 11 (ISO S5)

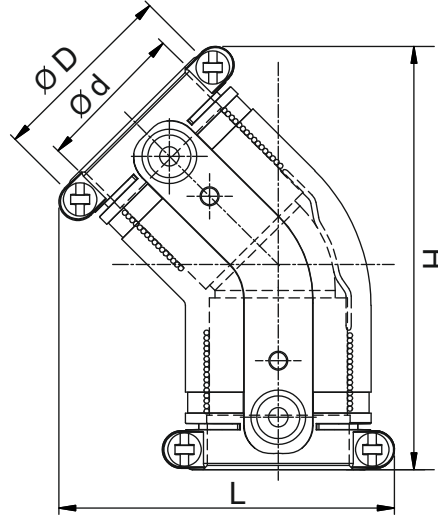

Kimplas Electrofusion 45° Elbows are manufactured in PE 100 Black material and are of SDR 11 rating (PN 16). For exact recommendations on compatibility, for welding with SDR 9 through SDR 21 or PN 6 through PN 16 pipe, refer Kimplas Technical Specifications Manual. Kimplas Electrofusion fittings are suitable for permanently connecting MDPE 80 and PE 100 pipes, both in straight form as well as in coil form.

SPECIFICATION TABLE

d	Product Code	SP	Weight (gm)	D(mm)	H (mm)	L (mm)	FT	CT
20	E20D45BKD	140	55	31	87	55	22	4
25	E25D45BKD	85	72	36	96	61	28	4
32	E32D45BKD	85	85	44	101	80	42	4
40	E40D45BKD	60	125	53	116	93	52	7
50	E50D45BKD	30	181	65	130	105	55	7
63	E63D45BKD	24	303	81	153	128	70	7

BKD - PE 100 Black - 4mm Pin

SP=Standard Pack Quantity, FT=Fusion Time in Seconds, CT=Cooling Time in Minutes, SP and Weight are given for reference only

Note: Every effort has been made to ensure the information in this brochure is correct at the date of issue. Kimplas operates a policy of continual product improvement and range extension, hence reserves the right to modify product specifications, without prior information, in line with market requirements.

STANDARDS

- Complies with EN1555- Part 3 for Gas, EN12201- Part 3 for Water. AS/NZS 4129 for Gas & Water GIS-PL2-Part 4 for Gas
- PE pipe compatibility- IS: 14885, EN 1555-2, IS: 4984, EN 12201-2, ISO: 4437 DIN: 8074, ISO: 4427-2.

COMMON APPLICATIONS

- Make 45° turn on mains and distribution Pipes in distribution network.
- Take branch connection in areas difficult to access, in narrow trenches and House Service Connections.
- Pipe connections with spigot end fittings, pipes stub ends etc.

INSTALLATION

Joint preparation must be done as specified in the installation instructions. Pipe outside surface must be scraped to remove oxidised layer. Before fusing, pipe ends and spigot end of the fittings must be cleaned to remove dirt and Contamination. Complete Installation Manual may be downloaded.

ADVANTAGES

- Standard operating voltage - 40 V.
- Provided with Screws for quick connection of pipes. No need of external clamps.
- Fitting with integral clamping for holding and exact fitment of fitting with pipe.
- More connections with less effort. Save time on site.
- Brings down inventory of tools and associated costs.
- Clearance Fit for ease of installation and removable centre stops for easy repairs.
- Same fusion time for various SDR rated pipes.
- Optimal fusion and cold zone for a strong and sturdy joint.
- Permanent Batch Indicator, Raw Material Type and SDR marking.
- Each fitting individually packed in PE bag to protect against contamination and oxidation.

Contact Us

Kimplas Piping Systems Private Limited - A member of NORMA Group -

B-20, MIDC , Ambad, Nashik- 422010 | India | www.kimplaspiping.net

Tel : +91 253 6622701/2 | Fax: +91 253 6604710 | Email: sales.kimplas@normagroup.com

